

Sensor/actuator module for DIN-rail mounting

The LCN-HU is a sensor/actuator module for building installation in Bus technology. It is a member of the Local Control Network.

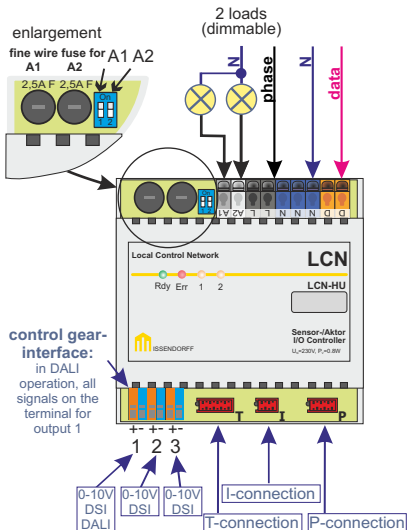

Application

The LCN-HU module is for installing in dry rooms in distribution boxes. It takes 5 Hp's of space.

It includes 4 dimmers, from which 2 are available over 230V electronic outputs.

The outputs can be operated as leading edge dimmers or in switching mode as zero voltage switches. They each include timers, which make it possible to set different dimming ramps and timer switches.

On the control gear interface, you can optionally give out 0-10V, DSI or DALI.

Additionally 3 sensor connections are available, which can be independently used if needed.

The connection

The LCN-HU module has three connection blocks: the power supply side with screwless terminals, the sensor side with three plug connections and the control gear interface with small screwless terminals:

Descr:	Colour:	Function:	
D	orange	data wire	(loop through)
N	blue	neutral wire	(loop through)
L	black	phase (L1, L2 or L3)	(loop through)
2	white	output 2	(switches fuse secured phase)
1	grey	output 1	(switches fuse secured phase)

and on the red plug connection side:

1	orange / blue	output 1: 0-10V, DSI or DALI for all 4 outputs
2	orange / blue	output 2: 0-10V or DSI
3	orange / blue	output 3: 0-10V or DSI

Note:

The 0-10V/DSI outputs 1, 2 and 3 (DALI only output 1) give the internal dimming value of the 3 (4) outputs. The power outputs 1 and 2 can dim or be set up so they can fully switch on, as soon as the dimming value not zero is. In this way the energy supply for the control gear interface can be taken over from the controlling output.

Outputs:

for DALI output see “Notes about DALI” on page 10.

The power connections are voltage fixed up to max. 4kV: Additional measures against overvoltage in operational conditions are not necessary. Measures for lightning protection in the building should be applied as usual. LCN does not need any additional protection.

The power outputs voltage fixed up to 500V AC (max. pulse voltage according to IEC801-4: 1kV). Because the electronic switches in the LCN modules switch off on the current zero crossing, no noise levels, even when using inductive loads, are to be expected.

Outputs:

Each output on the LCN-HU module is separately secured with a **fine fuse 2,5A F**. The LCN-HU module is supplied separately and works even when the fine fuse is not fitted. HU-modules detect defective fuses and show this locally through a flashing control lamp. The affected output switches **off** and sends a status message. The switching on will be rejected with the function message “fuse defect” in the hand operation on the LCN-PRO.

Apart from that, the LCN-HU monitors its operating temperature. If this gets too high due to an overload, both outputs will be switched off and a status message sent to the Bus:

“Module reports overload/over temperature”.

After cooling down, the outputs can be switched back on. Basically, the loads should always be checked beforehand.

Notes about the outputs:

The electronic outputs do not need a **minimum load**. This makes it possible to connect small and even inductive loads directly.

Due to the required measures for interference suppression according to CE, a small standby current of 4mA (capacitive) flows in every power output. This can cause **relays** to “stick” when connected to 230V. Solution: You can deactivate the dim interference filter. According to CE you must then only use the output in the switching mode.

Take a look at the circuit board: on the left next to the fuse holder, you will find a two way mini sliding switch, which is marked with 1 and 2 (see illustr. on page 1). When you slide the switch 1 downwards (away from the ON marking), the interference condenser from output 1 is deactivated. the same with switch 2 for output 2.

When connecting gas discharge lamps with control gear, the reactive current should be considered, the connectable load is reduced to half. Solution: Compensate the lights by simply connecting a condenser parallel or in series. with electronic zero-voltage switches, the problem with contact burn-up when using capacitive loads, will not occur. That´s why you can connect large condensers to the LCN outputs in switching mode (not in dimming mode!) For this reason a parallel compensation is possible.

Sensor technology :

The red sensor connecting plugs are protected only in a low extent against overvoltage. A contact with 230V will destroy the module. The sensor terminals are on the N potential, which means they are not decoupled from the electrical isolation. The same goes for the 0...10V/DSI/DALI outputs. That's why you must make sure, that a protection against contact for the user in every operating condition is ensured. The push-buttons from all of the approved switch panel systems ensure this protection. The module has three sensor connections, which can be used as additional switchings, if necessary as actuator. The functions can be programmed with the setup programme LCN-PRO.

T-connection:

About a key converter (LCN TU4H - no longer available) conventional push buttons can be queried.

I-connection:

Here the IR-receiver for the remote control can be connected, the 4-way binary sensor (LCN-BT4H/-BU4L), additionally the binary sensor LCN-B3I, the motion detector LCN-BMI, the transponder-reader LCN-UT/-ULT and the temperature sensor LCN-TS. These components can be operated parallel on the I-connection by using the LCN-IV. The I-connection can alternatively be served as a counter for pulses up to 1kHz, when no further periphery is connected.

P-connection:

Here you can connect for example, the current sensor (LCN-BS4) and the relay blocks (LCN-R8H/-R4M2H/-R2H. LCN-BS4 will be detected automatically. The LCN-R8H has to be activated first with the LCN-PRO.

Notes about the sensor technology:

The LCN-HU module monitors overloads and short circuits on its sensor technology (0...10V/DSI/DALI, T-, I-, P-port). Should the module be short circuited on its periphery, due to wiring errors, it will switch off the power supply from the sensor for 4 seconds by itself. Should the error still exist the periphery will be switched off for a further 8 seconds. If the error is not rectified after this time, the periphery will switch off for 30 seconds and a status message will be sent to the bus:

`"module reports overload/short circuit periphery."`

apart from that the red LED will flash cyclic, as long as the sensor technology is switched off. In this case check the connected sensor technology and the wiring. The module stays accessible and operational even after these errors!

Note:

As always with electronic, suppressor elements (e.g.VDR's) are to be planned with coils from 230V AC contactors and relays, that are installed in the same distribution boxes as the LCN modules.

Properties of the built-in control programme:**Measured value processing**

variables:	12
pre processing:	value correction, hum sound suppression,
evaluation:	2 formulars, mean value education
thresholds:	4 register à 4 thresholds (=10 commands) with hysteresis
regulators:	two continuous regulators, used seperately
counting/computing:	subtraction, addition, set to zero

Remote control

key-codes:	12 (with LCN-RT)
access control:	16 various LCN-RT, -ZTK or -ZTS evaluated directly „small access control“ any number of various LCN-RT, -ZTK or -ZTS evaluated with LCN-GVS „big access control“

Properties of the built-in control programme:

Issued numbers:	module ID: 5..254, group nr.: 5..254 segment nr.: 5..124
group members:	12 (fixed) plus 10 (dynamic)
command tables:	A, B, C & D with each 2 * 8 targets (each 3 commands) and 32 targets at 3 commands (double operation)
links:	depending on: logic, time, sensors, output- conditions, panel and fault report-processing (4-way) according to DIN.
scene storage:	10 x 10 per light group (brightness & ramp)

Timers (amount):

outputs (2):	10ms..40 min
keys (4):	each 1s .. 45 days
key blocking (1):	each 1s .. 45 days
output blocking (2x1):	1s .. 45 days (part & full blockage)
clock (1):	0,3s .. 6500 s
relay (2):	30ms ..4 min

Status display of the lamps**GREEN (flashes constantly):**

nr. of flashes	<u>message</u>
1	normal operation
2	self testing-error, module is not programmed
3	Bus error: module cannot send
5	module is in programming mode

RED (flashes only when occurrences are entered):

nr. of flashes	<u>message</u>
1	key was pressed, command was sent
2	different errors: please check with PC and the LCN-PRO
3	received telegram data was faulty
4	IR-telegram received from unauthorised sender
5	received illegal command (will be ignored)
6	error in the structure of a received command
7	parameter of a command exceeds permitted limit
8	command received cannot be carried out at the moment
cyclic (30s.)	periphery (T-,I-, P-port or 0...10V/DSI/DALI) was overloaded and/or short circuited.

Both the **yellow** LED's show switch and dimming conditions of the outputs.

Notes about DALI:

Only the output 1 will be switched. All DALI ballast are connected parallel to this control line: DALI ballast are addressable.

LCN sends group commandos to the DALI interface when operating. The groups 1, 2, 3 and 4 are fixed groups: All ballasts, that are a member of group 1, follow the 1st. output, the ones in group 2 the 2nd. and in group 3 the 3rd. LCN output. These all the extensive LCN functions (timers, ramps, light scenes, etc.) are available, without using DALI-commands. The outputs are controlled and the DALI ballasts follow them.

Important: The control gears from individual manufacturers differ: Use the correct control unit from each manufacturer for selecting the addresses.

Technical data**connection:**

power supply:

230V AC $\pm 15\%$, 50/60Hz (110V AC available)

power consumption:

0,8W

terminals/wire type (load side):

screwless, solid max. 2,5mm² oder fine wire with end sleeves max. 1,5mm²
loop through current max. 16A

fuses on the outputs:

fine wire fuses 2,5A F each output

connection sensor side:

T-, I- und P-connection

terminals/wire type (contr. interface):

solid or fine wire max. 0,5-1,5mm²**Outputs:**

type:

zero voltage switch or **leading** edge dimmer

triggering:

200 steps in the dimming operation

switching power:

each 500VA (cos ϕ =1)

overload:

each 1kW max.10s

reactive power:

1% of the apparent power

minimum load:

- not needed -

Technical data:

operating mode 0-10V DC:	voltage fluctuations max. $\pm 8\%$ source current: max. 0,5mA/output (aktive operation: HU supplies the current) <u>load current</u> : max. 40mA/output (around 40 control gears, passive operation : control gears supply the current)
operating mode DSI:	max. 20 control gears together
operating mode DALI:	max. 16 control gears together

Installation:

operating temperature:	-10°C..+ 40°C
air humidity:	max. 80% rel., non condensing
environmental conditions:	use as stationary installation according to VDE632, VDE637
protection art:	IP20
dimensions (BxDxH):	85,5mm (5HP) x 92mm x 66,5mm
installation:	DIN rail 35mm (DIN50022)

Important note:

Despite its extensive functionalities, the LCN system is simple to install and programme: It's all in the hands of the electrician. However a **training course is necessary for every electrician**, who installs this system. The direct users support over the telephone hotline, is only free of charge and open to installers who have taken part in a training course.

Technical information and images are non binding. Changes are reserved.
Technical hotline: +49 5066 998844 or www.LCN.de