

Low voltage power supply (12V/24V) for DC motors

Regulated with built in current sensor.

The LCN-NH12/-NH24 module converts 230V outputs for shutter and blind motors into low voltage. (12V DC or 24V DC, module description: LCN-NH12 or LCN-NH24, (please be aware when ordering.) The LCN-NH12/-NH24 module has an integrated direction toggler (+/-) with locking: controlling both direction inputs at the same time, is no problem. Apart from that, the power supply has an internal current sensor, that can be evaluated over an external binary sensor (LCN-B31/ -BU4L).

How it works with DC motors:

The LCN-NH12/-NH24 is connected to the outputs of an LCN-SH, -SHS or -HU module (see illustr.) The outputs of the module must be set to motor switch and **filters deactivated** (see data sheet LCN-SH / -HU). The motor is to be connected to terminals as described in the illustration. The controlling of the electrical motors is carried out over the commands motor / shutter (move UP, move DOWN or single control mode). Alternatively the power supply input feeds can be carried out through any other contacts, e.g. LCN-R8H.

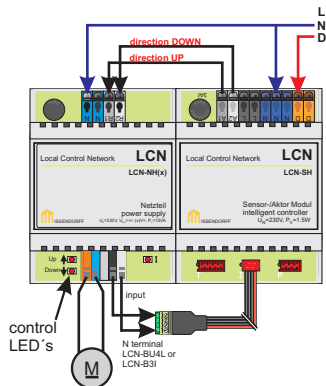

Polarity:

when phase (L) on terminal R1

then

orange = minus (-), blue = plus (+)

when phase (L) on terminal R2

then

orange = plus (+), blue = minus (-)

A special feature is the integrated current sensor, that can be evaluated over an external binary sensor (LCN-B3I/LCN-BU4L). This type of monitoring can be used for example for error messages like (motor is running / is not running!). For this, the binary sensor is connected to the terminals as shown on page 1.

The white terminal on the common (N/M) connection from the LCN-B3I/-BU4L, the black terminal on the desired input (motor is running = input is activated).

Note:

A parallel connection from LCN-NH12/-NH24 modules, is only possible over an interposing relay. (e.g. LCN-R4M2H)

Connecting as power supply:

The LCN-NH24 can also be used as a simple power supply, as query voltage for a sensor module (LCN-BU4L).

The power supply offers an electrical isolation from the query voltage to the mains power.

The power supply is connected primary side on the R2 (phase) and to the N terminal. On the secondary side, the blue terminal (see illustr. on the right) is connected to the M terminal of the LCN-BU4L. The orange terminal then branches off to the single push-buttons/switches.

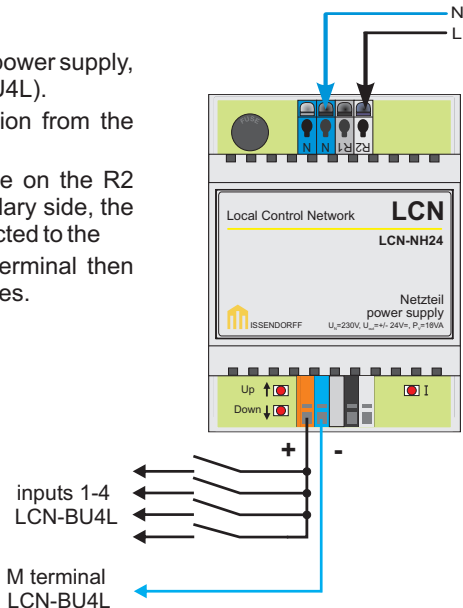

Technical data:**connection:**

power supply:	230V AC $\pm 15\%$, 50/60Hz
terminals/wire type (mains side)	screwless, solid max. 2,5mm ² or fine wire with wire eind-sleeves max 1,5mm ² loop through current max. 16A
terminals/wire type (load side)	solid or fine wire max. 0,5-1,5mm ²
nominal voltage NH12:	12V DC (stable)
nominal voltage NH24:	24V DC (stable)
nominal power:	10VA
fuse:	fine-wire fuse 2,5AF

installation:

operating temperature:	-10°C..+ 40°C
air humidity:	max. 80% rel., non condensing
environmental conditions:	use as stationary installation accord. to VDE632, VDE637
protection art:	IP20
dimensions:	68mm (4HP) x 113mm x 66mm
installation:	on DIN rail 35mm (DIN50022)

Technical information and images are non binding. Changes are reserved.
Technical hotline: +49 5066 998844 or www.LCN.de